

## Junction Box for Select Cameras

### FOR USE WITH CAMERA MODELS:

N2IP4B, N2IP4AFB, N2IPKITCAM,  
HDBIR60WD, HDAFBIR120WD, HDEIR60



N2JB1





Shown with N2IP4AFB  
(Camera not included)

### FEATURES:

- Manages & Protects Cables
- 3/4" Conduit Access
- For Indoor & Outdoor Use

### SCREW / MOUNTING SYMBOL GUIDE:

Model	Screw/ Symbol
N2IP4B, HDBIR60WD	M4×10mm / 
N2IP4AFB, HDAFBIR120WD	M4×10mm / No Symbol
N2IPKITCAM, HDEIR60	M4×18mm / 

### SPECIFICATIONS:

	N2JB1
Material	Aluminum Alloy
Color	White
Load Bearing	3 kg (6.61 Lb.)
Product Dimensions	φ110 × 48mm (φ4.33 × 1.89")
Product Weight	0.3kg (0.66 Lb.)

### PACKAGE INCLUDES:

Item	Qty
Junction box	1
3/4" Conduit Caps	1
Plastic Conduit Cable Connector	1
Rubber Grommet (for cable φ4.5-5.5mm)	1
Rubber Grommet (for cable φ6-8mm)	1
Black Rubber Plug	1
Mounting Template	1
Torx Screws M4×18mm	4
Torx Screws M4×10mm	4
Torx Wrench	1
Mounting Hardware Packet	1

### DIMENSIONS:

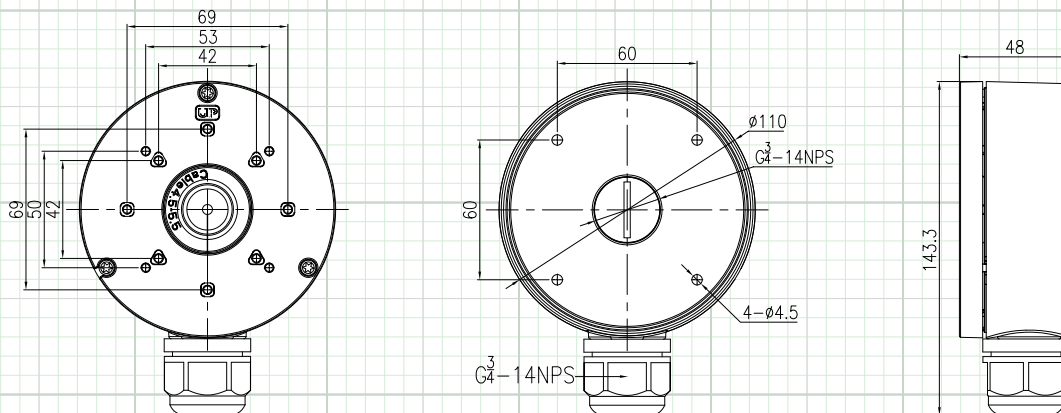

Note: Specification subject to change without notice